



The Comfortable Choice

**Window - Wall Type
Room Air Conditioner**

User's Manual

R32 Refrigerant **Models**

TWW16CFDG

TWW22HFWDG

TWW22CFWDG

TWW27HFWDG

TWW27CFWDG

TWW40HFWDG

TWW40CFWDG

TWW53HFWDG

TWW53CFWDG

TWW60HFWDG

TWW60CFWDG

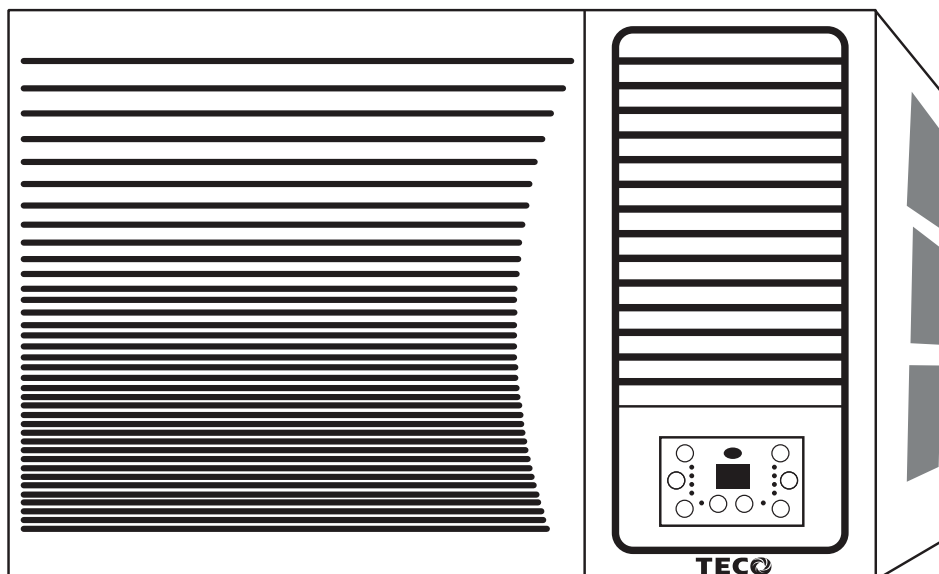

Thank you for selecting our super quality Air Conditioner. To ensure satisfactory operation for many years to come, this User's Manual should be read carefully before using your air conditioner. After reading, store it in a safe place. Please refer to the manual for questions on use or in the event that any irregularities occur.

Foreword

Congratulations on your purchase of a TECO room air conditioner. To assist you in protecting your investment and maintaining the appliances satisfactory operation, three simple steps are provided for you to follow.

1. Ensure that your air conditioner is installed according to the specifications detailed in this booklet.
2. Familiarise yourself with the correct operation of the air conditioners controls and switches.
3. Service your air conditioner at regular intervals.

Thank you for taking the time to read this booklet and we trust you enjoy the comfort obtained from your TECO room air conditioner.

The information contained in this material is provided by Teco Australia Pty Ltd in good faith. The information supplied to our knowledge is correct; however is subject to change without notice, therefore before relying on the material in any important matter, users should carefully evaluate its accuracy, completeness and relevance for their purpose. It is not intended as a substitute for consulting the relevant legislation or for obtaining appropriate professional advice relevant to your particular circumstances.

Teco Australia Pty Ltd cannot accept responsibility or liability for any loss, damage, cost or expense you might incur as a result of the use of or reliance on information provided. It is not intended to be, and should not be relied upon as the ultimate and/or complete source of information.



WARNING ICON
This symbol indicates information concerning your personal safety



CAUTION ICON
This symbol indicates information on how to avoid damaging the appliance



FLAMMABLE ICON
This symbol indicates appliance filled with flammable R32 refrigerant

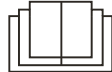

Read Before Use



Read Before Installation



Read Before Servicing

The Refrigerant



R32



WARNING

- The refrigerant used in this appliance is the mildly flammable **HFC R32** (difluoromethane). It is contained within the sealed system and does not pose a risk during normal operation or specified installation or maintenance procedures.
- Compared to other commonly used refrigerants, R32 has a lower global warming potential and a zero ozone depleting potential. R32 has good thermodynamic features which lead to a really high energy efficiency. The units therefore require less refrigerant than previously used with other refrigerants.
- If the refrigerant circuit should become damaged and a leak is observed, avoid open flames and sources of ignition.
- Disconnect the power to the appliance from the mains power. As this appliance uses a plug to supply power do not switch off from the appliance controls or the power point.
- Thoroughly ventilate the room in which the appliance is situated for several minutes before using other appliances or sources of ignition.
- Contact TECO customer service for advice.

Safety Precautions	---	---	---	---	---	---	4
Functions	---	---	---	---	---	---	6
Operating Conditions		---	---	---	---	---	7
Installation	---	---	---	---	---	---	8
Part Identification	---	---	---	---	---	---	11
Control Panel		---	---	---	---	---	12
Remote Control	---	---	---	---	---	---	13
Operation Tips	---	---	---	---	---	---	16
General Operation	---	---	---	---	---	---	17
Care & Maintenance	---	---	---	---	---	---	19
Troubleshooting	---	---	---	---	---	---	20

Safety Precautions

This appliance is not intended for use by persons (including children) with reduced physical, sensory or mental capabilities or lack of experience and knowledge, unless they have been given supervision or instruction concerning use of the appliance by a person responsible for their safety.

Children should be supervised to ensure that they do not play with the appliance.



WARNING

- **Do not start or stop the appliance by unplugging and plugging the power cord.**

This may result in fire and/or electric shock

- **Do not use any extension cords, power boards or adapters to connect this appliance.**

Do not connect via an extension lead. Extension leads do not guarantee the required safety of the appliance (e.g. danger of overheating, this can result in fire and/or electric shock).

- **Do not damage or modify the power cord or plug. Do not tamper with, tie or twist the power cord. Do not place heavy items on the power cord or subject the power cord to heat.**

This can result in fire and/or electric shock.

- **If the supply cord is damaged, it must be replaced by a special cord or assembly available from the manufacturer or TECO service center.**

- **Do not put your fingers or any objects, into the air outlet and inlet. Please do not touch the swing louvres.**

The internal fan rotates at a high speed, and thus such an action may result in an injury or malfunction

- **Do not attempt to repair, take apart, or modify the appliance.**

It may result in fire and/or electric shock. Refer servicing to your dealer or TECO Service Centre.

- **Do not put the appliance near heat generating devices (such as stoves, fan heaters, etc.).**

The plastic parts may melt causing fire.

- **Wipe dust off the power plug and insert the plug firmly into the power outlet socket.**

If the plug is not fully inserted in the power outlet socket, dust may gather on the connectors which in turn may cause fire and/or electric shock.

- **Should a malfunction occur (a smell of burning, etc.), switch off the appliance and unplug it from the power outlet socket.**

Continuing to operate a malfunctioning appliance may result in fire, electric shock, and further malfunction.

Contact your dealer or TECO Service Centre for consultation.

- **Do not cover the air inlet and the air outlet with clothes, curtains, etc.**

This results in poor ventilation and may cause heat generation and fire.

- **Do not put flower vases or any other objects filled with water on the unit.**

Water may leak into the appliance adversely affecting the electric insulation and cause electric shock and/or fire by short-circuiting.

- **Do not use the appliance for special purposes, such as preservation of food, art works etc.**

This may negatively affect the quality of the items stored.

- **If there is a possibility that the temperature around the drainage hose (field supplied) could drop to freezing point.**

Water inside the hose may freeze and prevent the water from flowing out. The water may leak from the appliance and damage surrounding objects.

- **Do not block the drainage outlet or continuous drainage hose (field supplied).**
- **If using the appliance or fixed drainage for a long time ensure the internal and external drain is clear.**

When using the appliance after a long period of time or when draining water continuously for a long time with no assistance, check the unit periodically for foreign objects, etc. that could clog the hose resulting in heat generation and/or a water leakage.

- **Do not use the appliance in places that may be subject to oil or flammable gas leakage.**

Such a leakage around the appliance may cause combustion and fire.

- **Do not wash the appliance with water.**

It may cause an electric shock.

- **Do not use the appliance where it is likely to come in contact with water.**

Exposure to water may result in fire or electric shock caused by a leak of electricity.

- **All electrical work should be carried out by a suitably qualified and competent person, in strict accordance with current national and local safety regulations.**

For extra safety it is advisable to install a suitable residual current device (RCD). Contact a qualified electrician for advice.

- **Ensure power is not supplied to the appliance until after installation work has been carried out.**
- **The appliance is supplied with a mains cable with moulded plug ready for connection to a single phase power supply within a voltage range of 220~240V/50Hz.**
- **Please ensure the electrical connection data plate information match the household mains supply.**
- **Connection should be made via a suitable switched socket which is easily accessible after installation.**



Introduction

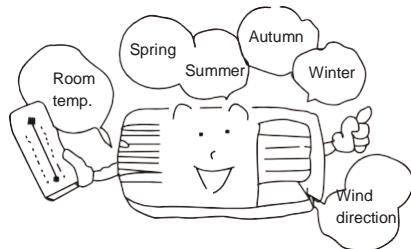

TECO's window - wall room air conditioners are engineered to maintain a comfortable temperature. Each unit comes packed with a host of features that make it easy for you to operate, set and forget. Simple and clever controls let you reach optimum comfort with ease.

Cool in Summer

During hot summer days, the air conditioner can cool down the room by circulating the air within the room and cooling it.



Dry During Wet or Humid Conditions (dehumidifying)

In wet or humid conditions, the air conditioner can dehumidify the air by drawing moisture from the air and leaving the room dry and fresh without effecting the temperature.

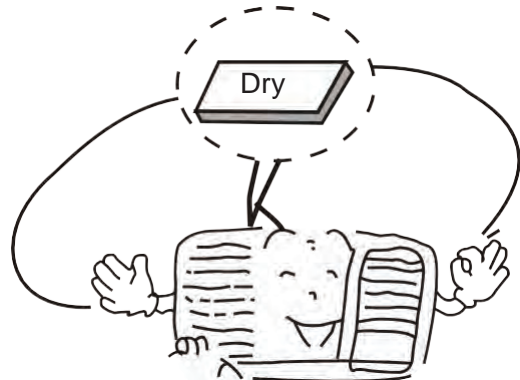

Warm in Winter (heat pump units only)

During cold winter months, the air conditioner can keep the room warm by circulating the cold air within the room and heating it.



During some lower outside temperature conditions it may be necessary to use supplementary sources of heating depending on application.

Exhaust Air Vent





Opening the exhaust air vent door to exhaust air from the room, allowing fresh air to enter.

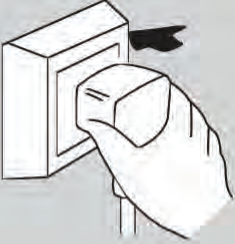

Please operate the air conditioner in the correct conditions as follows:

COOL & HEAT mode operation	DRY mode operation
<p>Outdoor air on temperature should be between 18°C ~ 43°C for cooling and 1°C ~ 24°C for heating. Operation outside these temperature ranges may effect the performance of the air conditioner. Room humidity should be lower than 90%. Otherwise, it is possible for the air conditioner to form moisture or dew on the front panel of the air conditioner. This indicates normal operation.</p>	<p>Outdoor air on temperature should be in the range of 18°C ~ 43°C. Operation outside these air on temperature ranges may effect the performance of the air conditioner.</p>

Power Requirements

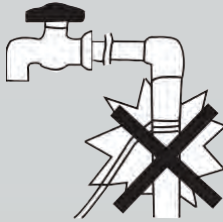
 CAUTION	<p>Rated voltage and voltage range: 220~240V. The electric components could be damaged when the voltage is too high. If the voltage is too low, the compressor could vibrate violently to damage the refrigerant system and easily cause the compressor and electric components not operate correctly.</p>	
 WARNING	<p>All earth leads must be connected. An approved power outlet must be used. Furthermore, the power outlet must conform to the wiring regulations. All electrical wiring and connections must comply to the current electrical Australian Standards and Wiring rules.</p>	
<p>Earth Wire To ensure the reliable earthing, please do not connect earth wire to water pipes.</p>		
 WARNING		

Installation

Teco Australia Pty Ltd will not warrant the equipment supplied, if the installation does not comply with the Building Code of Australia or any Local Government standard or code. The customer/contractor is solely responsible for ensuring that the equipment installed complies with all relevant building codes or standards.

IMPORTANT NOTICE



Due to various wall and window types and constructions, Teco Australia Pty Ltd recommends the window/wall type room air conditioner must be installed with compliance to the Building Code of Australia, Local Government or body corporate requirements. Please consult your local builder or air conditioning contractor.

All hardware required to install the air conditioner is field supplied.

Drainage

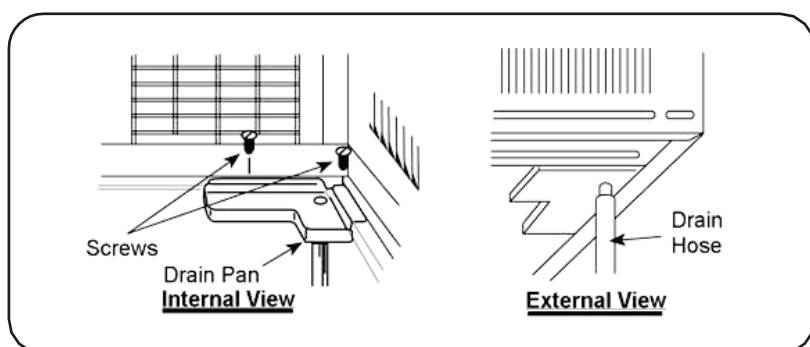

Drain Plug



(For illustration purposes only)

Drain Holes



To get the maximum cooling efficiency, the air conditioner is designed to splash condensate water on to the condenser coil during operation. Draining water away from the base may cause a slight loss in performance.

The cooling and heating model has two drain holes:

1. Thermostatically controlled drain mechanism. The drain will open <math><14\text{ C}</math> (approx.) to allow water to drain from the base and will close >math>>15\text{ C}</math> (approx.).
2. Drain hole with rubber plug fitted

The Cooling model has only one drain hole with rubber plug fitted.

Please remove the rubber plug fitted to the drain hole if the noise of splashing water bothers you or if the water droplets splashed through the condenser coil drops to the ground below causes a trip hazard or during Winter to release defrosted water quickly from the base.

To install a drain line please follow the steps below:

1. Slide out the chassis from the cabinet.
2. Remove the rubber plug from the body base plate.
3. Install the drain pan to the corner of the cabinet with 2 screws.
4. Slide the chassis into its original place in the cabinet.
5. Connect the drain hose (field supplied) to the outlet on the drain pan bottom.

WARNING: Do not push any object into the condensate drain hole as it may damage the condensation water thermostat mounted above.

A clear area is necessary around the exterior of the cabinet to allow adequate fresh air flow through the unit. The minimum clearances required are shown below.

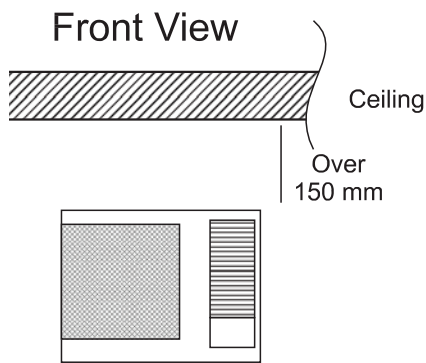
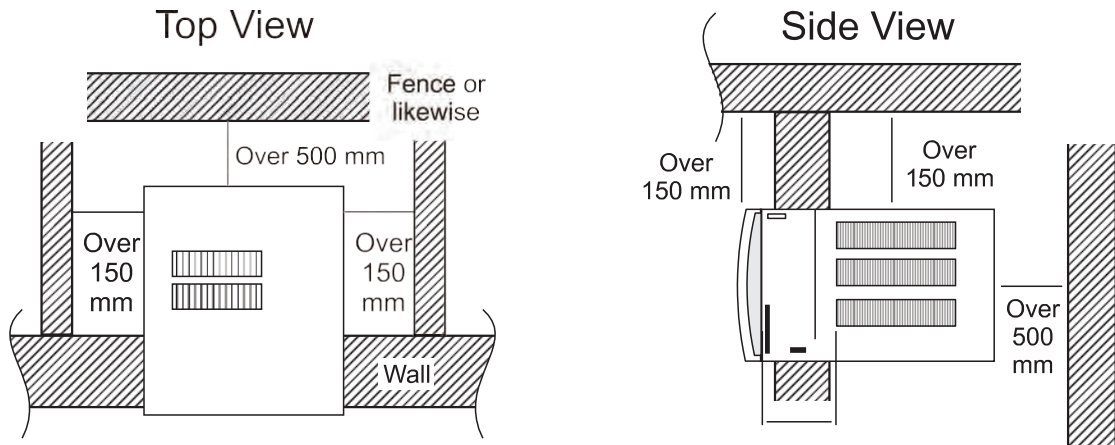

Tilt

When installing the unit, to clear condensate from the unit, the back edge of the cabinet should be approximately 6mm lower than the front edge.

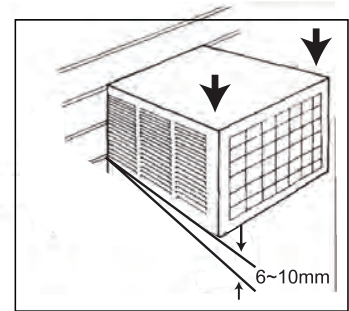

For safety and earthing purposes, all screws and washers, if removed during installation, maintenance, repairs, etc. must be refitted.

Internal Clearances

A clear area is necessary around the interior of the cabinet to allow adequate air flow through the unit. The minimum clearances required are shown below.

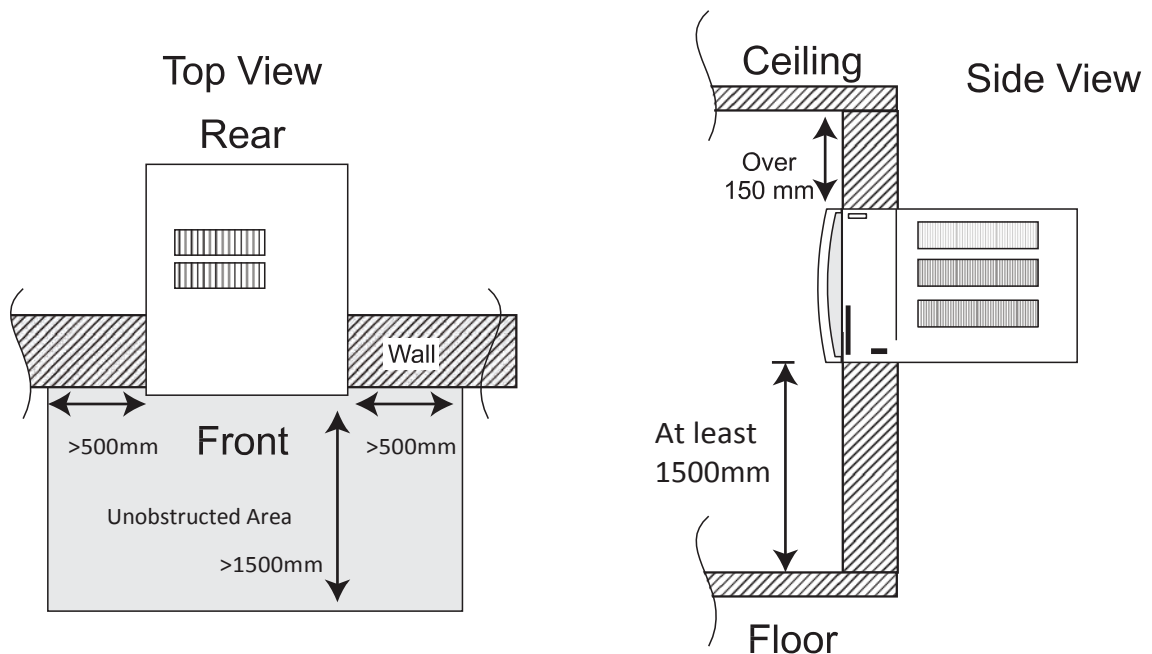

Removal Procedure

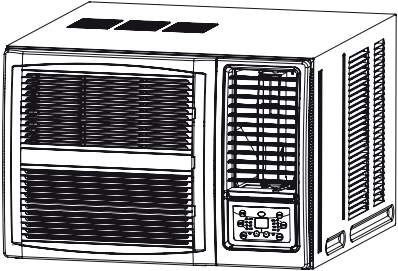
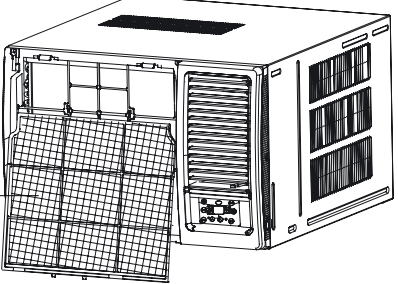
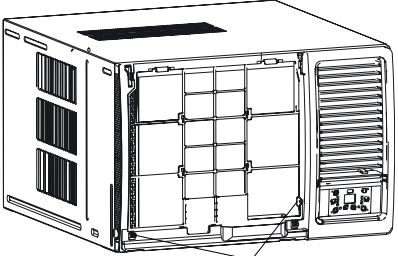
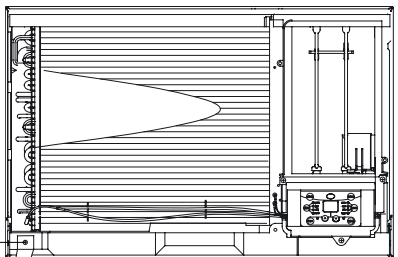
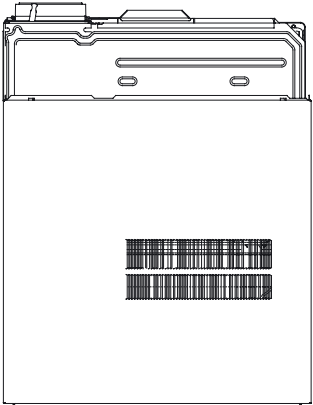
Steps	Procedure
<p>1. Remove panel assembly</p>	 <p>Air-inlet panel</p>  <p>Filter</p>  <p>screw</p>
<p>a. Remove the air-inlet grille</p> <p>b. Remove the filter</p> <p>c. Remove screws from either side and middle of front panel</p> <p>d. Push into sides and top of metal casing to release clips and remove front panel</p>	<p>2. Remove Cabinet</p>  <p>Clap fitted to chassis</p>
<p>e. Remove screw and clasp fitted to chassis</p>	 <p>f. Slide out air conditioner from casing</p>

● Part identification

For TWW16CFDG Only

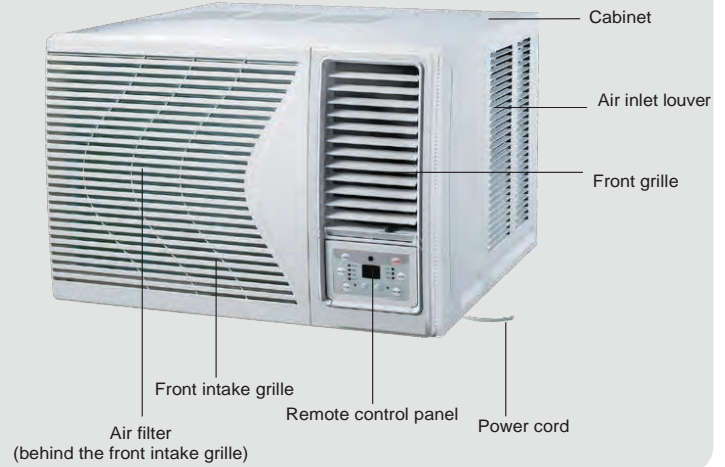
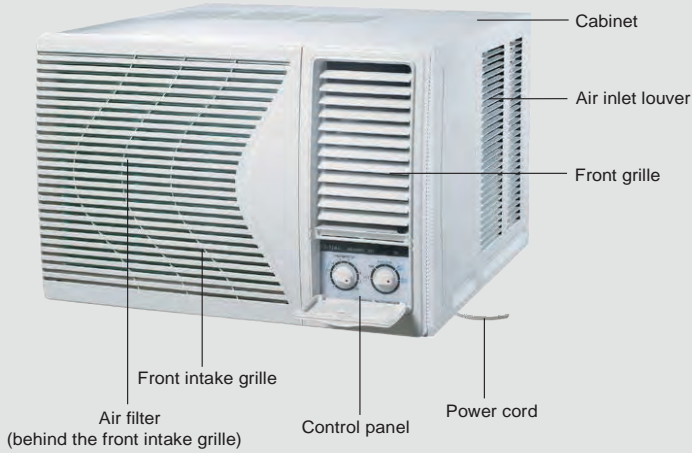

All images are for Illustration purposes only.

Air direction adjustment

Vertical airflow direction vane

(Airflow direction adjustment up and down).

The vertical airflow direction vane is controlled by positioning the vane to discharge the air upwards, downwards or straight out.

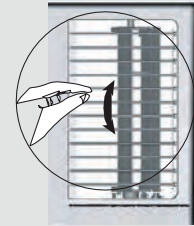

● Main switch operation procedure

For TWW16CFDG Only

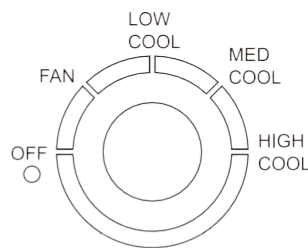
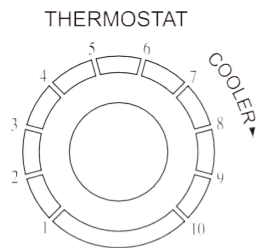

1. Main Control Knob

Set to select Low Cool, Med Cool, High Cool or Fan Only as desired.

CAUTION: WAIT at least 3 minutes before resetting to cooling operation, if it has been turned off or set to Fan.

2. Thermostat Knob

Set thermostat knob to select your desired room temperature (usually 6~7 is recommended). Adjust setting after a short period if your desired temperature cannot be obtained. The evaporator fins may be frozen up, if you set knob to 10. Turn it back counter-clockwise to resume normal operation.

AIR SWING



3. Air Swing Switch

(Airflow direction adjustment Side-to-Side)

To obtain a fix airflow direction, set the air swing switch to "ON" for the vanes to swing from side to side until the desired flow direction is reached, then switch it to "OFF". For continuous side-to-side air circulation, set the air swing switch to "ON".

Cooling Only Models

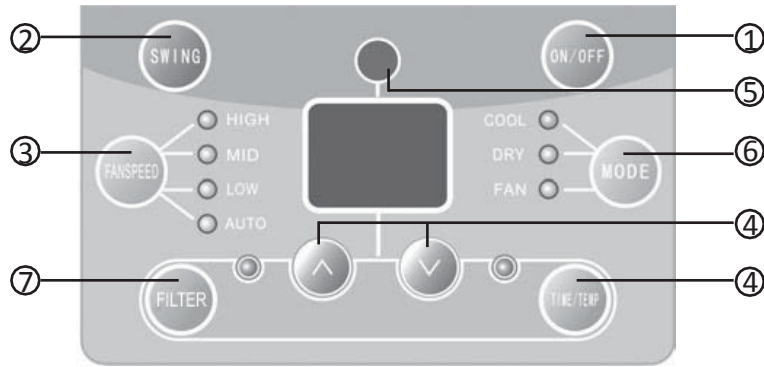

Cooling & Heating Models

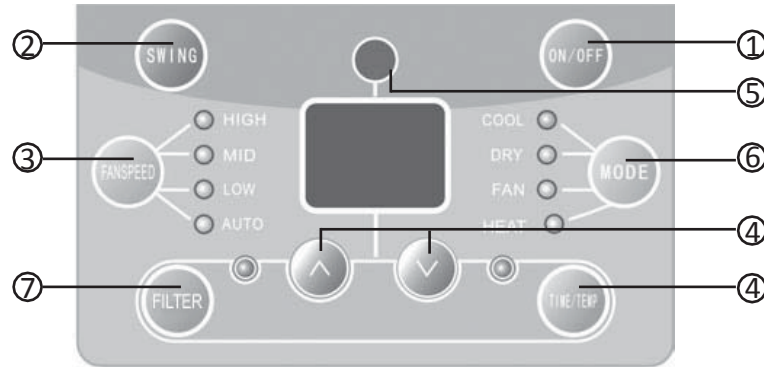

① POWER BUTTON

Operation starts or stops when this button is pressed

② SWING BUTTON

Activate the automatic air swing function

③ FAN SPEED BUTTON

Select the fan speed HIGH, MID, LOW and AUTO in sequence.

④ TIME/TEMP BUTTON

Press the \odot keypad to increase the set (operating) temperature of the unit and press the \ominus keypad to decrease the set (operating) temperature of the unit. The temperature setting range is from 16°C~30°C Press the \odot keypad also to increase the selected time in 1 hour increments and pressing the \ominus keypad to decrease the selected time in 1 hour decrements.

⑤ SIGNAL RECEIVER

⑥ MODE BUTTON

Select the operation mode, AUTO, HEAT, COOL, FAN, DRY (for reverse cycle model) or AUTO, COOL, FAN, DRY (for cooling only model).

⑦ FILTER BUTTON

This feature is a reminder to clean the Air Filter (see Care & Cleaning). The LED light will illuminate after 250 hours operation. To reset after cleaning the filter, press the Filter button and the light will go off.

If the filter requires cleaning prior to the 250 hours of operation, remove, clean and replace the filter. To reset the timer, press the Filter button for at least 3 seconds and the accumulated time of operation will be cancelled.

Ventilation Lever

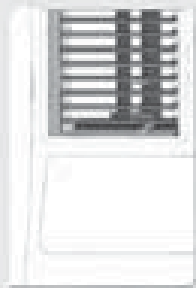

CLOSED ◀ VENT ▶ OPEN

Open Position:

The ventilation door opens to allow air and odors to be expelled from the room.



CLOSED ◀ VENT ▶ OPEN

Closed Position:

The ventilation door is closed and the air will be circulated inside the room and conditioned.

NOTE:

- Ensure there are no obstructions between receiver (air conditioner front panel) and remote controller.
- Do not drop or throw the remote control.
- Do not let any liquid in the remote control.
- Do not place the remote control in direct sunlight or any location with excessive heat.

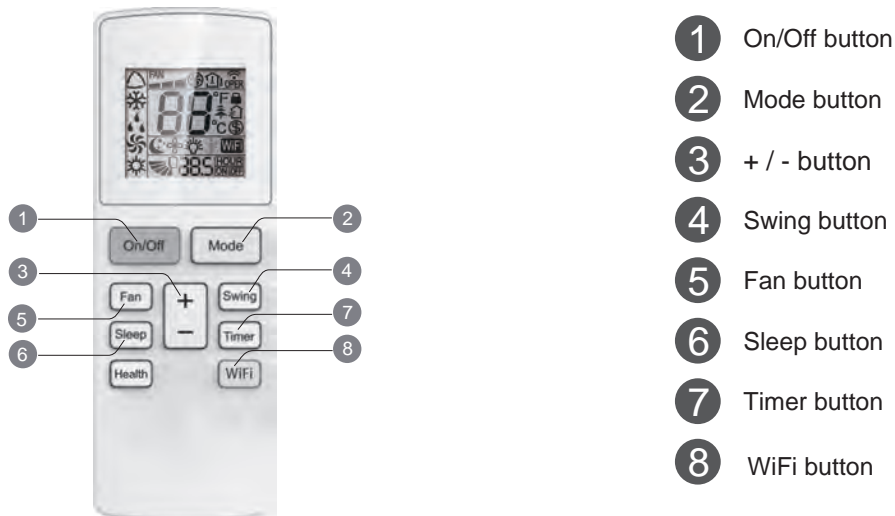

1 On/Off button

Press this button to turn on the unit. Press this button again to turn off the unit.

2 Mode button

Press this button can your required operation mode in turn. Corresponding indicator will be on.

- **Auto:** Under this mode, the unit will operate automatically according to ex-factory setting. In this case, set temperature cannot be adjusted.

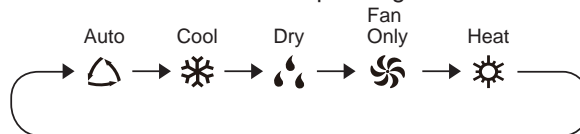

- **Cool:** Under this mode, air conditioner operates under cooling mode. Cooling indicator will be on. Press “Fan Speed” button can adjust the fan speed.
- **Dry:** Under this mode, the unit runs in low fan speed for dehumidification and the corresponding indicator is on; under dry mode, the fan speed cannot be adjusted.
- **Fan Only:** Under this mode, air conditioner will not cool or heat, only blow wind. Fan indicator will be on. Press “Fan Speed” button can adjust the fan speed.
- **Heat:** Under this mode, air conditioner operates under heating mode. Press “Fan Speed” button can adjust the fan speed (Cooling only unit won't receive heating mode signal. If set to heating mode with remote controller and ON/OFF button is pressed, the Unit will not start up)

NOTE: When in HEAT mode, the operation may stop from time to time to perform defrost function. During defrost H1 will be displayed. See page 16.

3 + / - button

- Pressing “+” or “-” button once will increase or decrease set temperature by 1°C (°F). Hold “+” or “-” button for 2s, set temperature on remote controller will change. Release the button after your required set temperature is reached.
- Under timer setting status, after each pressing of “+” or “-” button, time will increase or decrease 0.5h . Hold “+” or “-” button, 2s later, time displayed on dual-8 nixie tube will change quickly. Loosen the button until the time is reached to your set time.

4 Swing button

Press this button to turn “ON” & “OFF” swing.

Name & Function of Wireless Remote Control

(Not applicable to TWW16CFDG)

5 Fan button

This button is used for setting Fan Speed in the sequence that goes from AUTO, , , to  then back to Auto.

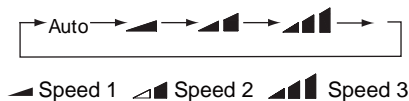

NOTE: There are 3 speeds for the Fan Speed of this model.

6 Sleep button

Press this button to go into the Sleep operation mode. Press it again to cancel this function. This function is available in COOL, HEAT (Only for models with heating function) mode to maintain the most comfortable temperature for you.

7 Timer button

Under ON status, press this button to set timer OFF; Under OFF status, press this button to set timer ON. Press this button once and the characters of HOUR ON (OFF) will flash to be displayed. Meanwhile, press "+" button or "-" button to adjust timer setting (time will change quickly if holding "+" or "-" button). Time setting range is 0.5~24 hours. Press this button again to confirm timer setting and the characters of HOUR ON (OFF) will start flashing.

If the characters are flashing but you haven't pressed the timer button, timer setting status will quit after 5s. If the timer is confirmed, press this button again to cancel the timer.

9 WiFi button

When WiFi function is turned on, "WiFi" icon will be displayed on the remote controller; when WiFi function is turned off by pressing the WiFi button, the icon will no longer be displayed.

How to turn on WiFi: Press "WiFi" button to turn on WiFi function.

How to turn off WiFi: Hold "WiFi" button for 5s to turn off WiFi function.

Under off status, press "MODE" and "WiFi" buttons simultaneously for 1s, WiFi module will restore factory settings.

- This function is not available for TWW16CFDG.
- Smart phone requirement.



iOS system
Support iOS7.0 and
above version



Android system
Support Android 4.4 and
above version

- Ewpe Smart App is required and installed on the smart phone.
Search "Ewpe Smart" in the application market to download and install it.
For more information please check Ewpe Smart App Operation Manual.

Function introduction for combination buttons

Temperature display switchover function

Under OFF status, press "-" and "Mode" buttons simultaneously to switch temperature display between °C and °F.

Light function

Under switch-on or switch-off state, you may hold "+" and "FAN" buttons simultaneously to set the lamp on or off and send the code. After being energized the lamp is defaulted on.

(Not applicable to TWW16CFDG)

Note:

- Range of time setting is: 0.5~24h
- The interval between two motions can't exceed 5s, otherwise the remote controller will exit setting status.

Combined Button Functions

Child Lock Function

Press “+” and “-” buttons simultaneously to turn on or turn off child lock function. When child lock function is active, the LOCK indicator will be displayed on the remote. No signal will be sent from the remote while it is in Child Lock.

Switching between centigrade and

While the air conditioner is off, press both “MODE” and “-” buttons simultaneously to switch between °C and °F.

Getting Started

1. Connect the power to the air conditioner. Press the ON/OFF button on the remote controller to turn on the unit.
2. Press the MODE button to select between AUTO, COOL, DRY, FAN or HEAT.
3. Press + or - buttons to set the required temperature.
The temperature cannot be set under AUTO mode.
4. Press FAN button to set from the following fan speeds
Auto, Low, Medium and High.

Changing the remote controller batteries

1. Press the remote controller back cover downward while sliding the cover in the direction of the arrow.
2. Remove the exiting batteries.
3. Insert two new AAA 1.5V batteries. Ensure the batteries are inserted in the correct direction as in the image to the right.
4. Replace the back cover once the batteries are securely in place.

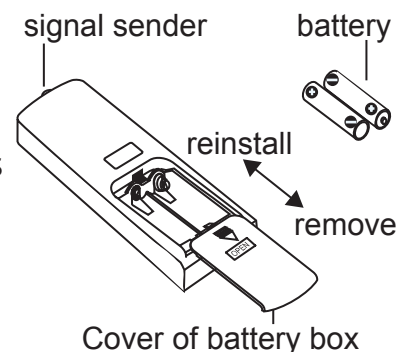

Notes



CAUTION

- When changing the batteries, do not mix new and old batteries. Do not mix brands or battery types.
- If the remote control is not used for long periods, remove the batteries to reduce the chance of leakage and damage to the remote.

- The remote has a limited range. This range reduces over time as the batteries lose charge.
- When using the remote, keep away (>1M) from other wireless appliances.
- When the remote does not operate, remove the batteries, wait 30sec. and replace them. If problems persist, replace with new batteries.

Operation in heating mode

- The amount of heating provided in HEAT mode will vary depending on environmental conditions existing at the time of operation.
- Performance is dependent on the amount of heat available in the outside air and the output heat capacity of the machine compared to the size of the space being heated.
- Heat absorbed by the outside heat exchanger (coil) will be reduced by frost buildup dependent on the amount of moisture in the outside air entering the machine.
- From time to time the microcomputer will stop the heating operation to defrost the outside heat exchanger, during this process some noises may be apparent when the operation is reversed.
- During defrost, **H1** will be displayed, heating function will resume in short time. This function is normal and not a fault. Please do not turn off Unit.

Do not set the cooling temperature too low. It could damage your health and waste electricity.

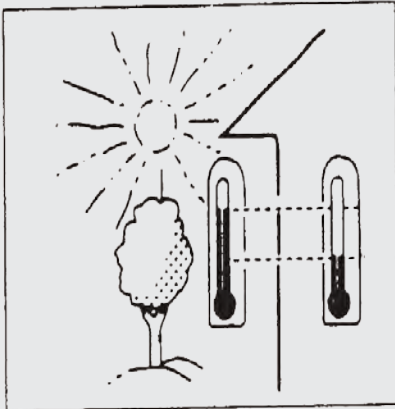

Keep blinds and curtains closed. Do not let sunshine directly in the room while the air conditioner is operating.

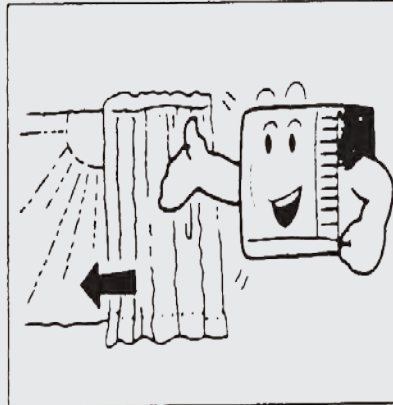

To keep the room temperature uniform, adjust the vertical and horizontal airflow direction to ensure uniform temperature in the room.

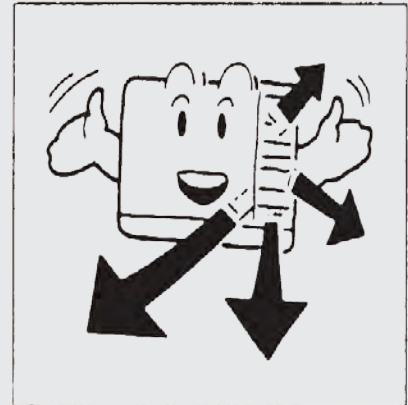

Make sure that the doors and windows are tightly closed. Avoid opening doors and windows as much as possible to keep the conditioned air in the room.

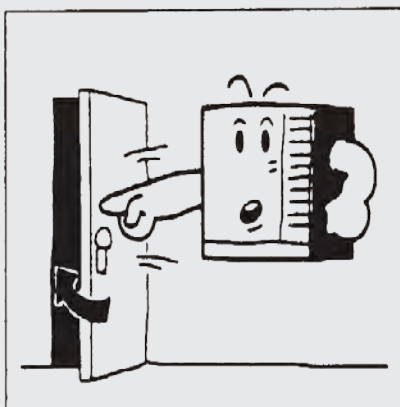

Clean the air filter regularly. Blockages in the air filter reduce dehumidifying effects. Clean the air filter at least once every two weeks.

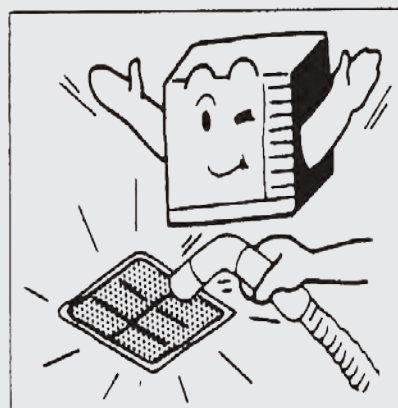

Ventilate the room occasionally. Since windows and doors are kept closed, it is a good idea to open them and ventilate the room every few hours.



Caution: Operation for Safety & Health



CAUTION

- 1) The plug must be accessible after the appliance is installed.
- 2) Do not use this appliance in a laundry or location with high moisture or humidity.
- 3) If the power cord is damaged, it must be replaced by the manufacturer or qualified service agent. Never attempt to repair the power cord. Do not operate the unit if the power chord is damaged.



WARNING

- Do not pull the power cord out by the cord.
- Damage to the cord may occur. This can cause electric shock.
- Do not use the air conditioner for other purposes except for cooling or heating the room.
- Do not use the appliance for other purposes such as drying clothes or preserving food, etc.
- Do not block the air intake and outlet vents. This reduces appliance performance and causes irregular operation.
- Do not insert any objects into these vents as it is dangerous to touch the electric components and fans.

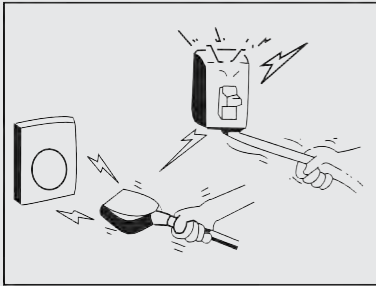

Adjust the temperature to suit the conditions. Rooms occupied by infants, the elderly, or the sick should be kept at an appropriate temperature.



Do not use heating equipment in the vicinity of the air conditioner. The plastic parts could distort if exposed to excessive heat.

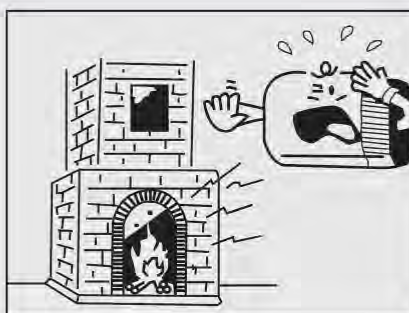

Avoid exposing the body directly to a continuous unidirectional air flow for long periods. This is not recommended for health reasons.

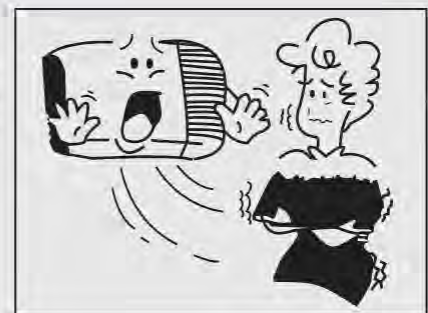

Always wait at least 3 minutes before switching the air conditioner on again after you have switched it off during cooling or heating.



To ensure safety, always turn off the air conditioner and main power supply before performing maintenance on the appliance.

1. Power off before cleaning.

Pull out plug only after air conditioner has stopped.

2. Use a soft cloth when cleaning the cabinet. If the cabinet is very dirty, dip cloth into warm water (below 40°C).

Dry the cloth by hand before cleaning.

3. Don't use gas, benzene, solvent, cleanser, chemical solvent, etc. for cleaning.

4. Do not splash water directly into indoor unit, there are micro-computers and circuit boards which must not get wet.

Don't wet the front panel. Only wipe with a cloth.

Air filter
The air filter behind the intake grille should be washed at least once every two weeks or as often as it needs cleaning.
How to clean the air filter:

- To remove the air intake grille, grasp the tab on the filter and pull to take out.
- Vacuum the filter on the side containing the dust.
- Wash the filter, cleaner side up under gentle flowing water to wash out accumulated dust and lint.
- If the filter is very dirty, use a mild household detergent in the water used to wash the filter.

Let the filter dry thoroughly before reinstalling it into the air conditioner. If necessary, please ask your local service center personnel to assist.

* Check the earth wire.





Is it damaged, broken or lose?

* Check if air inlet and outlet of outdoor unit are clear.

Air lock can result in poorefficiency and reduced performance.

Troubleshooting

Please check the following items before asking for repair or contacting service, it may save you time and money. If problems persist, consult your warranty information for contact details.

Fault	Solution
<p>Air conditioner does not operate at all.</p> 	<ul style="list-style-type: none"> ▪ Power failure ▪ Power plug disconnected ▪ Check fuse and main switch ▪ Inconsistent voltage
<p>Air conditioner efficiency is poor.</p> 	<ul style="list-style-type: none"> ▪ Check air inlet and outlet are not blocked ▪ Other cooling/heating sources in the room ▪ Check air filter is clean ▪ Indoor fan is set to LOW ▪ Room temperature is too high or too cool as the air conditioner starts.
<p>Odors or foggy air is released from the air conditioner.</p> 	<ul style="list-style-type: none"> ▪ When in cooling mode, high room humidity that is rapidly cooled, can appear foggy. ▪ Odors and smoke near the air intake can be transferred into and through the air conditioner.
<p>Air conditioner operates with excess noise.</p> 	<ul style="list-style-type: none"> ▪ The sound of flowing water is the refrigerant flowing through inside the air conditioner. This is a normal function of the appliance. ▪ The sound of falling water is caused by the dehumidifying unit processing the collected water. This is a normal function.
<p>It seems that condensation is leaking from air conditioner.</p>	<p>Condensation occurs when the air flow from the air conditioner cools the warm room air.</p>
<p>Air conditioner does not operate for about 3 minutes when restarting.</p>	<ul style="list-style-type: none"> ▪ This is to protect the mechanism. ▪ Wait about three minutes and operation will begin.

CAUTION : If any of the following occur, immediately power off the air conditioner and unplug from the wall. Contact your local service center.



CAUTION

- Operation starts or stops abnormally.
- Power fuse or switch often trips.
- Fluids are splashed directly into the air conditioner.
- Electrical cord is hot or cord insulation is damaged
- Other unusual noises emitted from the air conditioner.



WARNING

Did you know?

TECO Australia's product range also includes:

- ◆ Top Load Clothes Washers
- ◆ Front Load Clothes Washers
- ◆ Twin Tub Clothes Washers
- ◆ Auto Sensing Vented Clothes Dryers
- ◆ Refrigerators
- ◆ Chest and Vertical Freezers
- ◆ Bar Fridges
- ◆ Televisions
- ◆ Air Curtains and Air Conditioners

Visit **www.teco.com.au** for our full range.

REPAIRS, SERVICE & WARRANTY

It is hazardous for anyone installing, removing, altering, repairing, servicing or testing of this appliance.

Only an Authorised Service Person can carry out servicing or repairs to this appliance.

IF SERVICE IS REQUIRED:

If you have a problem, and the problem persists after you have made the checks mentioned in this manual, contact:

TECO Australia's Service on 1300 660 037 (8:30am - 4pm Mon~Fri AEST)

For warranty details please visit www.teco.com.au

Service Email : had.service@teco.com.au

Spare Parts : had.parts@teco.com.au



WARRANTY INFORMATION

Teco's warranty information for the product purchased is available at www.teco.com.au.

A copy of the warranty may also be obtained by contacting Teco's Warranty and Service Department on 1300 660 037 during business hours (Mon - Fri 8.30am – 4pm AEST).

To arrange for servicing of a Teco product, please contact our Warranty and Service Department on 1300 660 037 during business hours (Mon - Fri 8.30am – 4pm AEST).

To assist in processing any warranty claim that you may have Teco recommends that you:

1. Complete the following information in relation to your purchase:

Name of retailer: _____

Name of owner: _____

Date of purchase: _____

Model No. : _____

Serial No. : _____

MFG code: _____

2. Retain proof of your purchase for any warranty claim. Ideally this proof of purchase will be the tax invoice issued for your purchase.

3. Complete the following information in relation to the person that installed your Teco appliance (if applicable):

Installer's name: _____

Telephone No.: _____

Licence No.: _____



www.teco.com.au