

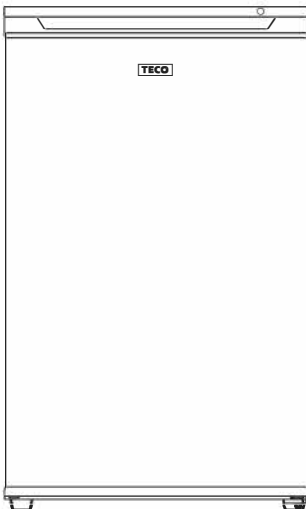

Engineered To Perform

UPRIGHT FREEZER

User Manual



Model:

TVF91WMAH

TVF91BMAH

TVF91SMAH

IMPORTANT NOTE:

Thank you for selecting a TECO quality appliance. Read this manual carefully before installing or operating your new appliance. Make sure to save this manual for future reference.

The design and specifications are subject to change without prior notice for product improvement. Consult with the place of purchase, sales representative or check the TECO website for details.





CONTENTS

Important Safety Instructions	1
Overview	5
Reversing the Door	6
Installation Instructions	8
Operating Instructions	9
Maintenance and Care of the Appliance	10
Troubleshooting	12
Repairs, Service & Warranty	13
Specifications	14

IMPORTANT SAFETY INSTRUCTIONS

- Thank you for purchasing our product and thank you for placing your confidence in us.
- Read this manual carefully before use. Follow instructions and keep the manual for future reference.
- Follow the operating instructions and safety notices in this manual.
- If any trouble arise, do not attempt to fix it yourself. Please contact TECO service on 1300 660 037 (8:30am - 4pm Mon~Fri AEST).
- This freezer is designed and approved for use with flammable R600a refrigerant.
- The appliance is specifically constructed for domestic use only. The appliance has not been designed or manufactured for professional use. TECO declines all responsibility for damage deriving from improper use of the appliance. The freezer has undergone the necessary tests on the tightness of the refrigeration circuit and complies with the safety regulations for electrical appliances.
- All images, illustrations and photos contained in this manual are for illustration purposes only and may differ from your appliance.

	This is a prohibition symbol. Any non-compliance with instructions marked with this symbol may result in damage to the product or endanger the personal safety of the user.
	This is a warning symbol. It is required to operate in strict observance of instructions marked with this symbol; or otherwise damage to the product or personal injury may be caused.
	This is a cautioning symbol. Instructions marked with this symbol require special caution. Insufficient caution may result in slight or moderate injury, or damage to the product.

- This appliance contains a small quantity of flammable, non-synthetic R600a refrigerant.
 - The room for installing the appliance must be at least 1m³ per 8g of refrigerant. The amount of refrigerant in the appliance can be found on the rating plate attached to the appliance.
 - If the refrigerant circuit should become damaged. Avoid open flames and sources of ignition. Disconnect the appliance from the mains power. Thoroughly ventilate the room in which the appliance is situated for several minutes.



Warning: risk of fire / flammable materials.

IMPORTANT SAFETY INSTRUCTIONS

- The Class 1 freezer is designed to operate on a single phase power supply within a voltage range of 220~240V/50Hz.
- The refrigeration system contains refrigerant. Do not allow any sharp objects to come in contact with the refrigerant system to avoid damage the refrigerant circuit.
- This product is for indoor use only.
- Do not place electrical items or cooking equipment nearby. Keep away from substances which could cause ignition and good ventilation shall be always maintained.
- Do not place objects on top of the appliance which are magnetic, heavy or filled with water.
- Power cord must not be lengthened.
- Make sure that the power plug is not squashed or damaged by the back of the appliance. A squashed or damaged power plug may overheat and cause a fire.
- Make sure that you can come to the mains plug of the appliance.
- Do not pull the mains cable.
- If the power plug socket is loose, do not insert the power plug. There is a risk of electric shock or fire.
- If the supply cord is damaged, it must be replaced by authorised TECO service personal, service agent or similarly qualified persons in order to avoid a hazard.
- Do not store flammable, explosive, volatile and highly corrosive materials in the refrigerator. Containers with flammable gases or liquids can leak at low temperature. There is a risk of explosion or fire.
- Do not splash water on the appliance. It may cause malfunction or electric shock.
- Always switch off and unplug appliance before cleaning.
- Keep ventilation openings, in the appliance enclosure or in the built-in structure, clear of obstruction.
- Do not use mechanical devices or other means to accelerate the defrosting process, other than those recommended by the manufacturer.
- Do not use electrical appliances inside the storage compartments of the appliance.
- For appliances which use flammable insulation blowing gases, Please keep the products away from the fire or similar glowing substance.
- This appliance is intended to be used in household and similar applications such as:
 - staff kitchen areas in shops, offices and other working environments;
 - farm houses and by clients in hotels, motels and other residential type environments;
 - bed and breakfast type environments;
 - catering and similar non-retail applications.

IMPORTANT SAFETY INSTRUCTIONS

- This appliance is heavy. Care should be taken when moving it.
- Do not remove nor touch items from the freezer compartment if you hands are damp/wet, as this could cause skin abrasions or frost/freezer burns.
- Avoid prolonged exposure of the appliance to direct sunlight.
-  • This appliance is not intended for use by persons (including children) with reduced physical, sensory or mental capabilities, or lack of experience and knowledge, unless they have been given supervision or instruction concerning use of the appliance by a person responsible for their safety.
- Young children should be supervised to ensure that they do not play with the appliance.
- Packing (e.g. wraps, polystyrene etc.) can be dangerous for children. There is a risk of suffocation. Keep packaging materials away from children.
- Contact your local authorities for correct method of disposal. Dispose of all packaging in a responsible manner in accordance with local regulations.

Installation

Important! For electrical connection carefully follow the instructions given in specific paragraphs.

- Unpack the appliance and check if there are damages on it. Do not connect the appliance if it is damaged. Report possible damages immediately to the place you bought it. In that case retain packing.
- It is advisable to wait at least four hours before connecting the appliance to allow the oil to flow back in the compressor.
- Adequate air circulation should be around the appliance, lacking this leads to overheating. To achieve sufficient ventilation follow the instructions relevant to installation.
- Wherever possible the spacers of the product should be against a wall to avoid touching or catching warm parts (compressor, con-denser) to prevent possible burn.
- The appliance must not be located close to radiators or cookers.
- Make sure that the mains plug is accessible after the installation of the appliance.

Daily Use

- Do not put hot on the plastic parts in the appliance.
- Do not place food products directly against the rear wall.
- Frozen food must not be re-frozen once it has been thawed out.
- Store pre-packed frozen food in accordance with the frozen food manufacture's instructions.
- Appliance's manufactures storage recommendations should be strictly adhered to. Refer to relevant instructions.
- Do not place carbonated or fizzy drinks in the freezer compartment as it creates pressure on the container, which may cause it to explode, resulting in damage to the appliance.

IMPORTANT SAFETY INSTRUCTIONS

Energy Saving

- Don't put hot food in the appliance;
- Don't pack food close together as this prevents air circulating;
- Make sure food don't touch the back of the compartment(s);
- If electricity goes off, don't open the door(s);
- Don't open the door(s) frequently;
- Don't keep the door(s) open for too long time;
- Don't set the thermostat on exceeding cold temperatures;
- Some accessories, such as drawers, can be removed to get larger storage volume and lower energy consumption.

Care and Cleaning

- Before maintenance, switch off the appliance and disconnect the mains plug from the mains socket.
- Do not clean the appliance with metal objects.
- Do not use sharp objects to remove frost from the appliance. Use a plastic scraper.

Service

- Any electrical work required to do the servicing of the appliance should be carried out by a qualified electrician or competent person.
- This product must be serviced by an authorized Service Center, and only genuine spare parts must be used.

Disposal



Refrigerant and Cyclopentane foaming material used for the freezer are flammable. Therefore, when the freezer is scrapped, it shall be kept away from any fire source and be recovered by a special recovering company with corresponding qualification other than be disposed by combustion, so as to prevent damage to the environment or any other harm.



When the freezer is scrapped, disassemble the doors, and remove gasket of door and shelves; put the doors and shelves in a proper place, so as to prevent trapping of any child.



Correct Disposal of this product

This marking indicates that this product should not be disposed with other household waste. To prevent possible harm to the environment or human health from uncontrolled waste disposal, recycle it responsibly in accordance with local regulations.

OVERVIEW

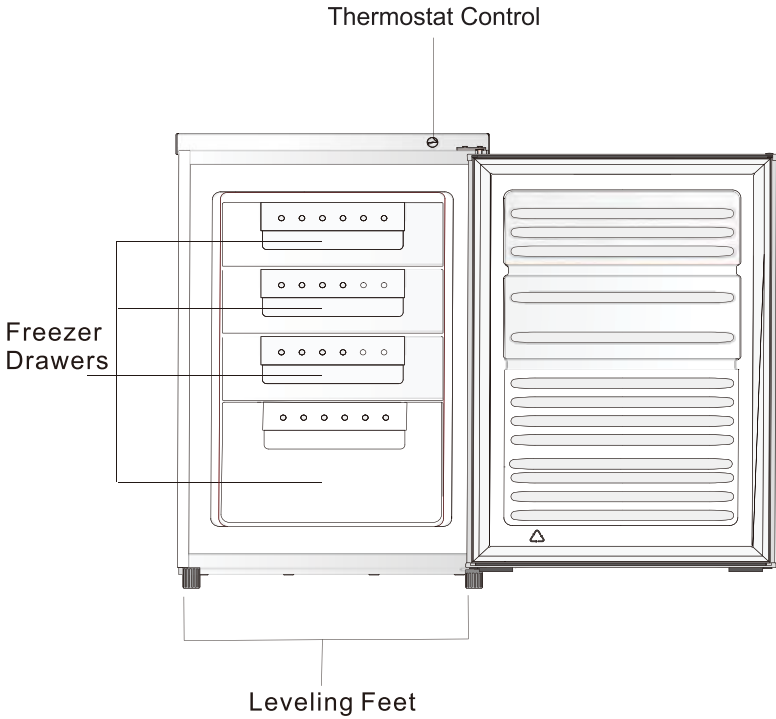

NOTE: The illustration in this manual are for reference only. Actual configuration will depend on the physical product.

REVERSING THE DOOR

Tool required: Philips screwdriver, Flat bladed screw driver, Hexagonal spanner.

- Ensure the unit is unplugged and empty.
- To take the door off, it is necessary to tilt the unit backwards. You should rest the unit on something solid so that it will not slip during the door reversing process.
- All parts removed must be saved to do the re-installation of the door.
- Do not lay the unit flat as this may damage the coolant system.
- It is better that 2 people handle the unit during assembly.

1. Remove two screws at rear side of the top cover.

2. Remove top cover and thermostat knob, then place it aside.

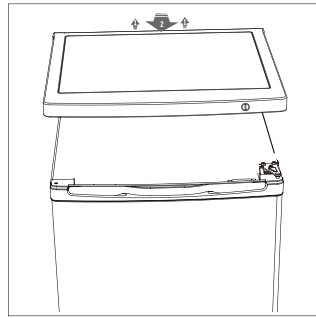
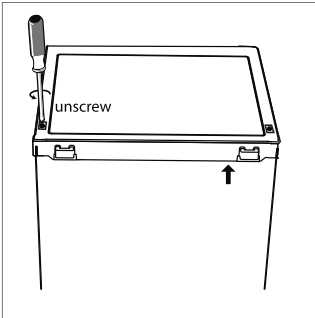

3. Unscrew top hinge and then remove door and place it on a soft pad to avoid scratch.

4. Unscrew bottom hinge. Then remove the adjustable feet from both side.

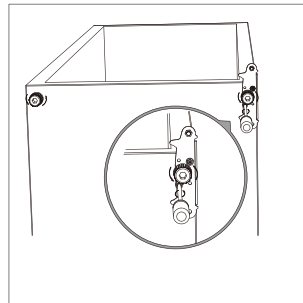
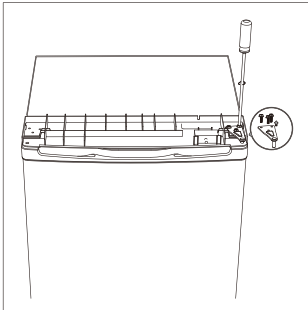

REVERSING THE DOOR

5. Unscrew and remove the bottom hinge pin, turn the bracket over and replace it.

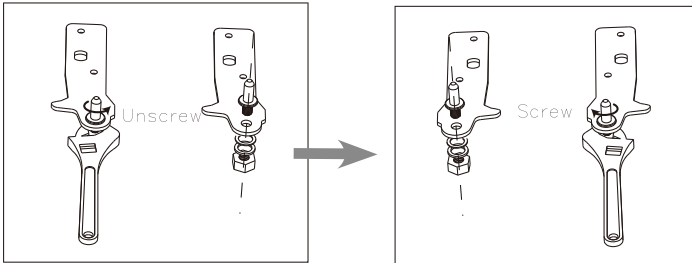

6. Refit the bracket fitting the bottom hinge pin. Replace both adjustable feet.

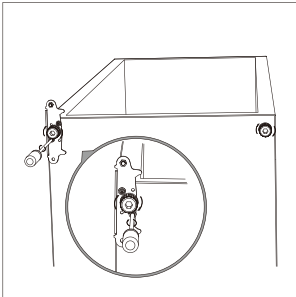

7. Place the door back on. Ensure the door is aligned horizontally and vertically so that the seals are closed on all sides before finally tightening the top hinge.

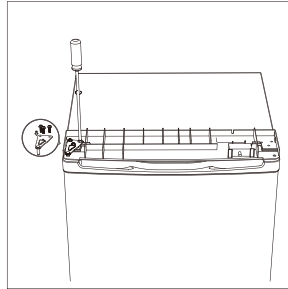

8. Put the top cover and fix it with 2 screws on the back.

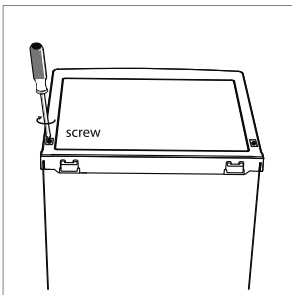

9. Fix the thermostat knob.

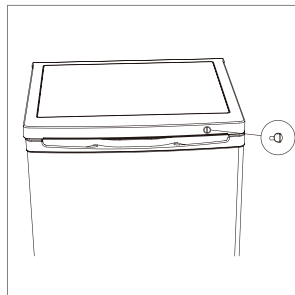

INSTALLATION INSTRUCTIONS

1. Before using the refrigerator for the first time, remove all of the packing materials, including the foam base and adhesive tape holding accessories in place.
2. The refrigerator should be located on a firm, flat surface that is strong enough to support the refrigerator when it is fully loaded.
3. Choose a location that is not exposed to direct sunlight, high temperatures, heat sources such as a stove or radiator, or in a moist area. Do not choose a location where the temperature will go below 12°C as this could cause the refrigerator to not function properly.
4. Leave a minimum of 50mm between each side of the appliance and the wall. The top of the appliance should have a minimum of 100mm clearance. This allows for proper air circulation. This appliance is intended to be free-standing and should not be built-in or placed in a recessed area.
5. The refrigerator legs must be adjusted during installation in order to function properly. The leveling legs on the front corners can be adjusted by turning clockwise to raise the appliance, and counter-clockwise to lower it. Be sure to have the appliance slope slightly backward to ensure that the door closes tightly.

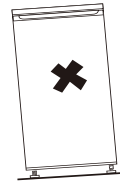
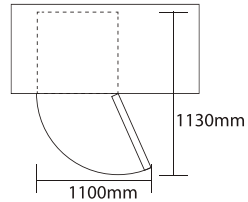

It must be possible to disconnect the appliance from the power supply; the plug must therefore be easily accessible after installation.

Electrical Connection

Before plugging in, ensure that the voltage and frequency shown on the rating plate correspond to your domestic power supply. The appliance must be earthed. The power supply cable plug is provided with a contact for this purpose. If the domestic power supply socket is not earthed, connect the appliance to a separate earth in compliance with current regulations, consulting a qualified electrician. The manufacturer declines all responsibility if the above safety precautions are not observed.

OPERATING INSTRUCTIONS

First Use

- Before using the appliance for the first time, wash the interior and all internal accessories with lukewarm water and some neutral soap so as to remove the typical smell of a brand new product, then dry thoroughly.
Important! Do not use detergents or abrasive powders, as these will damage the finish.
 - When first starting up or after a period out of use, before putting the product in the compartment let the appliance run for 2-3 hours, or for above 4 hours in summer when the ambient temperature is high to make sure it is working properly and to allow it time to fall to the correct temperature.
- ! Do not overfilled the freezer.
- Do not use any electronic equipment inside the appliance.
 - Do not store objects which are costly or subject to temperature variations. e.g. medication or chemicals.

Temperature Setting

- The internal temperature is controlled by a thermostat. There are 3 settings **MIN**, **NORMAL** and **MAX**.
- **MIN** is warmest setting and **MAX** is coldest setting.
- The appliance may not operate at the correct temperature if it is in a particularly hot area or if you open the door frequently.

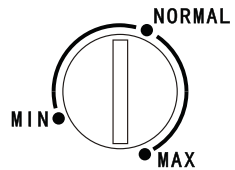

Placement of Food

- The freezer compartment is suitable for freezing fresh food and storing frozen and deep-frozen food for a long time.
- There should always be some space between items inside for air circulation.
- Food should be kept in sealed packaging to avoid becoming dry or spoil.
- Hot food should be cooled down before placing into the appliance. Otherwise, the interior temperature and power consumption will increase.
- Reduce opening the door frequently. Keeping the door closed will increase the appliance efficiency and reduce power consumption.

Energy Saving Tips

- The appliance should be located in the coolest area of the room, away from heat producing appliances or heating ducts, and out of the direct sunlight.
- Let hot foods cool to room temperature before placing in the appliance. Overloading the appliance forces the compressor to run longer. Foods that freeze too slowly may lose quality, or spoil.
- Be sure to wrap foods properly, and wipe containers dry before placing them in the appliance. This cuts down on frost build-up inside the appliance.
- Appliance storage bin should not be lined with aluminum foil, wax paper, or paper toweling. Liners interfere with cold air circulation, making the appliance less efficient.
- Organize and label food to reduce door openings and extended searches. Remove as many items as needed at one time, and close the door as soon as possible.

MAINTENANCE AND CARE OF THE APPLIANCE

Defrosting

1. Frost build-up on the walls will increase energy consumption and reduce the efficiency of the appliance. Defrost the section whenever the frost reaches a thickness of 5mm.
2. Switch the appliance off and unplug from the mains.
3. Remove the food from the refrigerator. Store them in a cool place, well covered.
4. Put a basin underneath or towels around the freezer to collect the defrost water.
5. The defrosting process can take several hours. Open the door to speed up the process.
6. When defrosting is completed, wipe the compartment with a soft cloth to remove any remaining water, dry the interior thoroughly.
7. Plug the power to the mains and reset the freezer to the desired setting.



Warning!

- Please unplug the freezer for defrost and cleaning.
- Do not use sharp or pointed objects to remove frost or ice from the surfaces of the ice making compartment. This can cause damage to the compartment walls and cooling coils, and will void the warranty.

Cleaning

- Dusts behind the freezer and on the ground shall be timely cleaned to improve the cooling effect and energy saving.
- Check the door gasket regularly to make sure there are no debris. Clean the door gasket with a soft cloth dampened with soapy water or diluted detergent.
- The interior of the freezer should be cleaned regularly to avoid odor. Please turn off the power before cleaning interior, remove all foods, shelves, drawers, etc.
- Use a soft cloth or sponge to clean the inside of the freezer, with two tablespoons of baking soda and a quart of warm water. Then rinse with water and wipe clean. After cleaning, open the door and let it dry naturally before turning on the power.
- For areas that are difficult to clean in the freezer (such as narrow sandwiches, gaps or corners), it is recommended to wipe them regularly with a soft rag, soft brush, etc. and when necessary, combined with some auxiliary tools (such as thin sticks) to ensure no contaminants or bacterial accumulation in these areas.
- Do not use soap, detergent, scrub powder, spray cleaner, etc., as these may cause odors in the interior of the refrigerator or contaminated food.
- Clean the shelves and drawers with a soft cloth dampened with soapy water or diluted detergent. Dry with a soft cloth or dry naturally.
- Wipe the outer surface of the freezer with a soft cloth dampened with soapy water, detergent, etc., and then wipe dry.
- Do not use hard brushes, clean steel balls, wire brushes, abrasives (such as toothpastes), organic solvents (such as alcohol, acetone, banana oil, etc.), boiling water, acid or alkaline items, which may damage the fridge surface and interior. Boiling water and organic solvents such as benzene may deform or damage plastic parts.
- Do not rinse directly with water or other liquids during cleaning to avoid short circuits or affect electrical insulation after immersion.

MAINTENANCE AND CARE OF THE APPLIANCE

Power Failure

When a power failure occurs, the refrigerator can normally store food for several hours. Do not put additional food into the appliance during a power failure, and do not operate door. Disconnect the plug from the outlet, and reconnect when the power has been restored. Always inspect for, and discard, any spoiled or thawed food in the refrigerator before resuming use of the appliance.

Vacation

Before leaving on any vacation, remove food that could spoil while you are gone. If you plan to be gone for an extended period of time, we recommend that all of the food should be removed from the appliance and it should be turned off and unplugged from the outlet. Clean the interior according to the directions provided in the CLEANING section of this manual, and leave the door open.

Moving the Freezer

- Turn off the freezer and unplug from the outlet.
- Remove all food; securely tape down all loose items inside.
- Tape the door shut.
- Do not lift or pull the door or door handle during transportation.
- When moving, the appliance cannot be tilted over 45 degrees as possible damage to the sealed system could occur.
- Take care to avoid strong vibration or impact to the appliance.

TROUBLESHOOTING



Warning!

For your safety, unplug the appliance from the mains power source. Only an Authorised Service Person can carry out servicing or repairs to this appliance. If you have a problem, and the problem persists after you have made the checks mentioned in this manual, contact: TECO Australia's Service on 1300 660 037 (8:30am - 4pm Mon~Fri AEST)

Problem	Possible cause	Solution
Appliance does not work	Mains plug is not plugged in or is loose	Insert mains plug.
	Fuse has blown or is defective	Check fuse, replace if necessary.
	Socket is defective	Mains malfunctions are to be corrected by an electrician.
Appliance freezes too much	Temperature is set too cold or the appliance runs at MAX setting.	Turn the temperature regulator to a warmer setting temporarily.
The food is not frozen enough.	Temperature is not properly adjusted.	Please look in the initial Temperature Setting section.
	Door was open for an extended period.	Open the door only as long as necessary.
	A large quantity of warm food was placed in the appliance within the last 24 hours.	Turn the temperature regulation to a colder setting temporarily.
	The appliance is near a heat source.	Please look in the installation location section.
Heavy build-up of frost on the door seal.	Door seal is not air-tight.	Carefully warm the leaking sections of the door seal with a hair dryer (on a cool setting). At the same time shape the warmed door seal by hand such that it sits correctly.
Unusual noises	Appliance is not level.	Re-adjust the feet.
	The appliance is touching the wall or other objects.	Move the appliance slightly.
	A component, e.g. a pipe, on the rear of the appliance is touching another part of the appliance or the wall.	If necessary, carefully bend the component out of the way.

The following are normal conditions that can be encountered during the operation of this appliance:

- The flow of refrigerant through the coils can cause a noise.
- The sides of the appliance may become warm as a result of the cooling function.

REPAIRS, SERVICE & WARRANTY

It is hazardous for anyone installing, removing, altering, repairing, servicing, testing or certifying the gas system of a gas device (i.e. charging, discharging or breaking into the refrigeration system that uses hydrocarbon refrigerants).

Only an Authorised Service Person can carry out servicing or repairs to this appliance. In Queensland the authorised person must hold a Gas Work Authorisation for hydrocarbon refrigerants, before carrying out servicing or repairs which involve the removal of covers.

IF SERVICE IS REQUIRED

If you have a problem, and the problem persists after you have made the checks mentioned in this manual, contact:
TECO Australia's Service on 1300 660 037 (8:30am - 4pm Mon~Fri AEST).

For warranty details please visit

www.teco.com.au

Service Email : had.service@teco.com.au

Spare Parts : had.parts@teco.com.au

SPECIFICATIONS

Model Number		TVF91WMAH TVF91BMAH TVF91SMAH
Capacity (L)	Refrigerator	-
	Freezer	91
Voltage (V)		220 - 240
Frequency (Hz)		50
Rated Input Power (W)		100W
Rated Current (A)		0.7
Noise [dB(A)]		≤41
Refrigerant		R600a
Climate class		T
Group		6U
Electric shock protection type		I
Waterproof Class		IPX0
Net Weight (kg)		33
Dimension (mm)	Width	550
	Depth	580
	Height	850

E&OE

NOTE: This product is subject to continuous improvement, specifications are subject to change without prior notice. This product was tested in accordance with Electrical safety of electrical appliances AS/NZS 60335, Energy consumption and performance AS/NZS 4474.1 and Energy labeling and minimum energy performance AS/NZS 4474.2.

Did you know?

TECO Australia's product range also includes:

- ◆ Top Load Clothes Washers
- ◆ Front Load Clothes Washers
- ◆ Auto Sensing Vented Clothes Dryers
- ◆ Heat Pump Clothes Dryer
- ◆ Refrigerators
- ◆ Chest and Vertical Freezers
- ◆ Bar Fridges
- ◆ Televisions
- ◆ Air Curtains
- ◆ Air Conditioners

Visit **www.teco.com.au** for our full range.



WARRANTY INFORMATION

Teco's warranty information for the product purchased is available at www.teco.com.au.

A copy of the warranty may also be obtained by contacting Teco's Warranty and Service Department on 1300 660 037 during business hours (Mon - Fri 8.30am - 4pm AEST).

To arrange for servicing of a Teco product, please contact our Warranty and Service Department on 1300 660 037 during business hours (Mon - Fri 8.30am - 4pm AEST).

To assist in processing any warranty claim that you may have Teco recommends that you:

1. Complete the following information in relation to your purchase:

Name of retailer: _____

Name of owner: _____

Date of purchase: _____

Model No. : _____

Serial No. : _____

MFG code: _____

2. Retain proof of your purchase for any warranty claim. Ideally this proof of purchase will be the tax invoice issued for your purchase.

3. Complete the following information in relation to the person that installed your Teco appliance (if applicable):

Installer's name: _____

Telephone No.: _____

Licence No.: _____



www.teco.com.au